

## WHAT'S NEW/ AMP™ MOTORIZATION

Finally, control your draperies in an instant from anywhere with our new AMP™ Motorization. Enjoy the ease and comfort of motorized draperies on our most popular rods. Our quiet yet powerful motor moves on command and whisks your draperies in an instant so you can experience comfortable living at its finest.

Now that's a smart move.



## AMP™ MOTORIZATION FEATURES

- ✔ AMP™ App with AMP™ USB Bridge.
- ✔ The slim design of the quiet, yet powerful motor and the position on the track allows the motor to tuck seamlessly behind your drapery panel, eliminating the need for the huge return flap needed on many competitive motorized tracks
- ✔ Easy to install motor simply clicks into the back of the coordinating track header and stays concealed behind the drapery panel
- ✔ Radio Frequency (RF) Remote and Wall Switches with fifteen channels
  - Easy programming and favorites setting
  - Smart motor sets end limits automatically
- ✔ Motor can be operated using the included cord free battery pack or directly plugged into a 120V AC outlet.
- ✔ Loss of power release disengages the motor from the carriers so the draperies may be opened in the event of an emergency
- ✔ Tug feature allows for smooth operation without the presence of a remote
- ✔ Available drapery headings:
  - Ripplefold™
  - Pleated
- ✔ Available on our most popular tracks:
  - Estate™ Traversing Rod in our Buckingham®, Designer Metals™, Wood Trends™, Varia and Chroma Collections
  - Architrac® Series 94001

## AMP™ MOTORIZATION SPECS

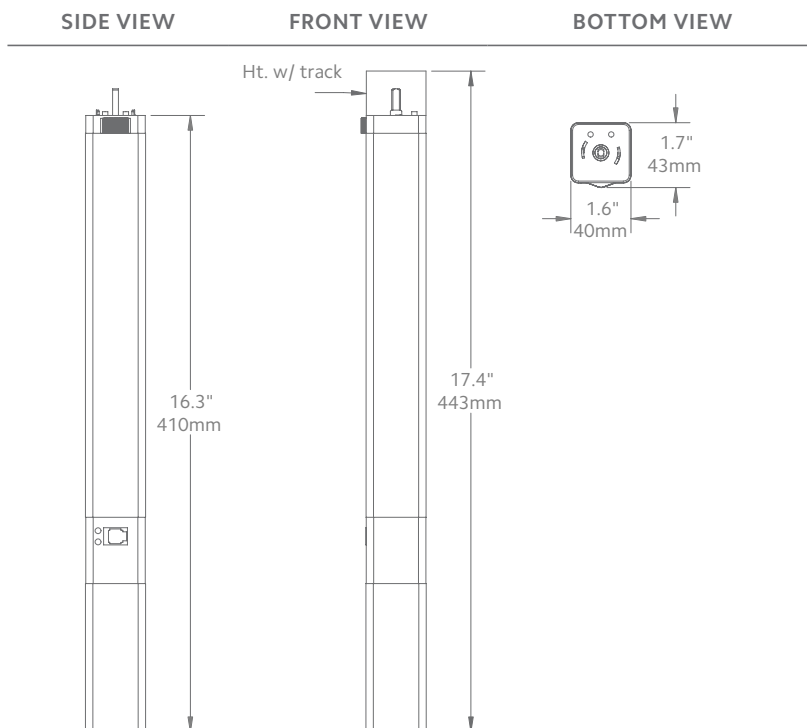

MOTORIZED TRACK FEATURES	AMP™ MOUNT
Power Supply	DC 16.5V=0.89A (100-240VAC 50/60Hz 0.5A)
Amperage	2.55Ah
Average Linear Speed	7.8 inches/sec
Power Consumption	40 watts
Torque	1.2Nm
Variable Speed	80, 100 & 120 rpm
Power Cable Length	6 feet
Certifications	UL/CE
Max Track Length	Estate™ – 16ft Architrac® 94001 – 40ft
Max. Load	64 lbs

Follow track specifications for drapery weight.

### Architrac® & Estate™ Track Performance with AMP™ Motorization

DRAW	MIN. TRACK LENGTH	MAX. TRACK LENGTH	MAX. LBS. PER FOOT
ONE-WAY	18"	16'	4 LBS.
TWO-WAY	18"	16'	4 LBS.

Download the AMP™ APP to get started

